



Innovation: **Fastening Elements**



Designing, Bolting, Joining

ITH Quality Management

The ITH quality-management system tested to ISO 9001 by DQS in Frankfurt specifies that the raw bar steel has to be supplied by reputable approved steel manufacturers correctly heat-treated, tested and ultrasonically inspected.

In order to avoid confusion, each individual bar is subjected to spectrographic analysis before entry into our stores.

In the case of special alloys or special customer requirements, the steel supplier receives a specification with which he must comply. The supplier certificates are checked for compliance with the order specification, and if the result of the spectrographic analysis is satisfactory, the material is released for storage or production.

At ITH, safety-critical fastening elements are allocated a special numerical code which makes it possible to trace the material back to the steelworks which produced it. Depending on customer requirement, acceptance testing can be carried out at ITH GmbH by any of the following organisations:

American Bureau of Shipping (ABS)

Germanischer Lloyd (GL)

Bureau Veritas (BV)

Norske Veritas (NV)

TÜV

Lloyd's Register (LR)



Large shelf stock and saw department



Spectrum analysis



Materials

The materials listed below represent only a small fraction of the materials used by ITH for its fastening elements, which are frequently made of special materials.

Tempering Steels			
Abbreviation	Material no.	UNS-no. USA	ASTM/AISI/SAE USA
42CrMo4	1.7225	H41400	A304/AISI 4140H / SAE J775/1268
32CrMo12	1.7361	–	–
34CrNiMo6	1.6582	–	–
30CrNiMo8	1.6580	–	–
50CrV4	1.8159	H61500	A304/AISI 6150H /SAEJ1268

High-Temperature, Extreme High-Temperature Steels			
Abbreviation	Material no.	UNS-no. USA	ASTM/AISI/SAE USA
24CrMo5	1.7258	H41300	A304/AISI 4130H / SAE J1268
21CrMoV57	1.7709	–	–
40 CrMoV47	1.7711	–	A193 Gr B16
X22 CrMoV12-1	1.4923	S42200	A126/565/ AISI 422 /SAE J467/775
X19CrMoVNbN11-1	1.4913	–	–
X8CrNiMoBNb1616	1.4986	–	–
NiCr20TiAl Alloy 80 A	1.4952	NO7080	B637/ SAE J467

Cryogenic Steels			
Abbreviation	Material no.	UNS-no. USA	ASTM/AISI/SAE USA
26CrMo4	1.7219	H41300	A304/AISI 4130H SAE J1268
X6CrNiTi18-10	1.4541	S32100	A128/193/194/213/240/249/269/276/312 376/479/ (further see material S32100 AISI 321/SAE J405/412/467)
X5CrMnNiN18-9	1.6909	S21900	A269/276/312/314/473/580/813/ 814

Stainless Steels			
Abbreviation	Material no.	UNS-no. USA	ASTM/AISI/SAE USA
X17CrNi16-2	1.4057	S43100	A176/276/314/473/479/493/511/579/580/593/594/AISI 431 / SAE J412
X5 CrNi18-10	1.4301	S30400	A182/194/213/240/249/312/320/336/358/368/376/403/409/430/473/497/492/493/511/554/580/632/666/688/774/793/813/814/851/908/943/965/988. AISI 304 SAE J405/412/467
X6 CrNiTi 18-10	1.4541	S32100	A182/193/194/213/240/249/269/276/312/313/320/336/358/376/403/409/430/473/479/493/511/554/580/632/774/778/813/814/943/965/ AISI 321 / SAE J405/412/467

Special Materials			
Abbreviation	Material no.	UNS-no. USA	ASTM/AISI/SAE USA
Alloy 718 NiCr19NbMo	2.4668	NO7718	B637/ B670/ SAEJ467
Alloy X-750 NiCr15Fe7TiAl	2.4669	NO7750	B637/ SAEJ467
Alloy 80 A NiCr20TiAl	2.4952/ 2.4631	NO7080	B637/ SAEJ467



CNC-lathe department



Dimensions / Mechanical Production



Close-tolerance bolts M 245 for water turbines

The high standard of quality and the large production facilities make it possible to manufacture special bolts in various sizes and tolerance classes.

ITH's supply spectrum begins with thread size M20 (3/4"). The largest thread manufactured to date by ITH was W510 (510 mm / 20.078").

The mechanical machining of the fastening elements is carried out on state-of-the-art CNC machines with driven tools.

The threads (up to M 120/5") are made by ITH using the cold-rolling process. Depending on size and material, the thread is cold-rolled by the continuous or recessing process. Through cold rolling, the root area of the thread is strengthened. This increases the yield strength of the bolt material in edge areas of thread flank and core fillet. At the same time, the internal compressive stresses are created which later overlap with the tensile stresses, thereby creating an overall tensile state (especially in the edge zones of the thread root), which has a positive effect on the life of the bolt.



Turning of expansion bolt on lathe

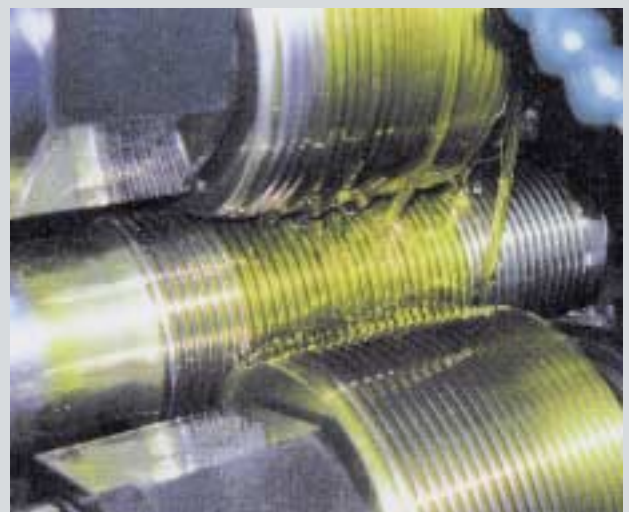

Thread rolling M 120 x 6



Selection Criteria for Fastening Elements

Some applications for ITH fastening elements are highly stressed roller bearings and turbine construction. As ITH manufactures both the fastening elements and the tools for installing them, the bolts are often designed in accordance with recommendations by ITH (system supplier). Fastening elements are designed to cope with the degree and type of stresses (static, dynamic, thermal) which arise.

The requirements for highly stressed joints are calculated on the basis of VDI 2230. The following description of individual fastening elements is intended to assist the user in selecting the right type of fastening element.

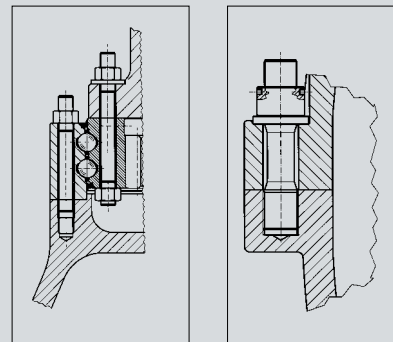

ITH fastening elements for large roller bearings (left), turbines (right)

Standard hexagonal nuts

To achieve an economical and technically acceptable joint, ITH recommends M39 hexagonal nuts to EN ISO 4032. From thread size M42, ITH advises using round nuts of type RMZ or RMS.

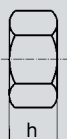
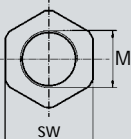
	M	h _{max.}	SW _{max.}	M	h _{max.}	SW _{max.}
	M 24	21,5	36,0	M 33	28,7	50,0
	M 27	23,8	41,0	M 36	31,0	55,0
	M 30	25,6	46,0	M 39	33,4	60,0

Hexagonal bolt

- Advantage**
- standardised and therefore frequently used
 - economical for short clamping lengths and small sizes
- Disadvantages**
- concentration of stresses in head
 - danger of cracking through upset head
 - limited angularity of thread axis to underlying surface
 - procurement of special materials
 - use not feasible at high bending loads

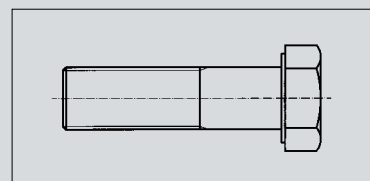

Selection Criteria for Fastening Elements

Hexagon socket bolts (Allen bolts)

- Advantage
- use in radially restricted spaces
- Disadvantage
- concentration of stresses in head
 - danger of cracking through upset head
 - limited angularity of thread axis to underlying surface
 - procurement of special materials
 - use not feasible at high bending loads

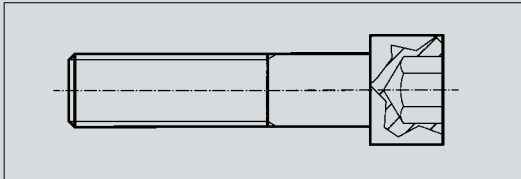

Expansion bolt

- Advantage
- use in thermally stressed joints
 - reverse bending stresses
 - dynamic stresses
 - procurement possible for special materials
- Disadvantage
- complex production due to expansion shaft

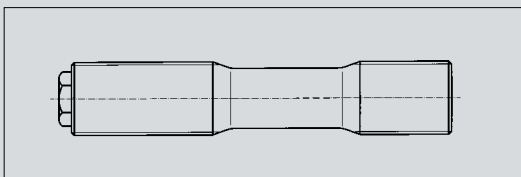

ITH Fastening Elements

ITH stud bolts

- are produced from thread-size M 20 (3/4")
The threads can be rolled up to M 120 (5").
Stud bolts have the following advantages:
- low-cost production as shaft diameter equals rolling diameter
 - low stress concentration for optimum layout
 - easy procurement and production with special materials

To obtain a quotation, please enter the principal dimensions of your bolt in the table.

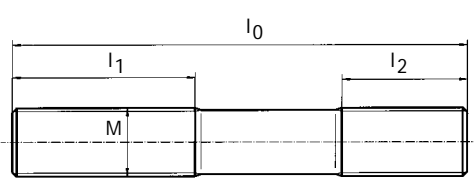

Thread M	Dimensions			Quantity	Material	Comments
	l ₀	l ₁	l ₂			

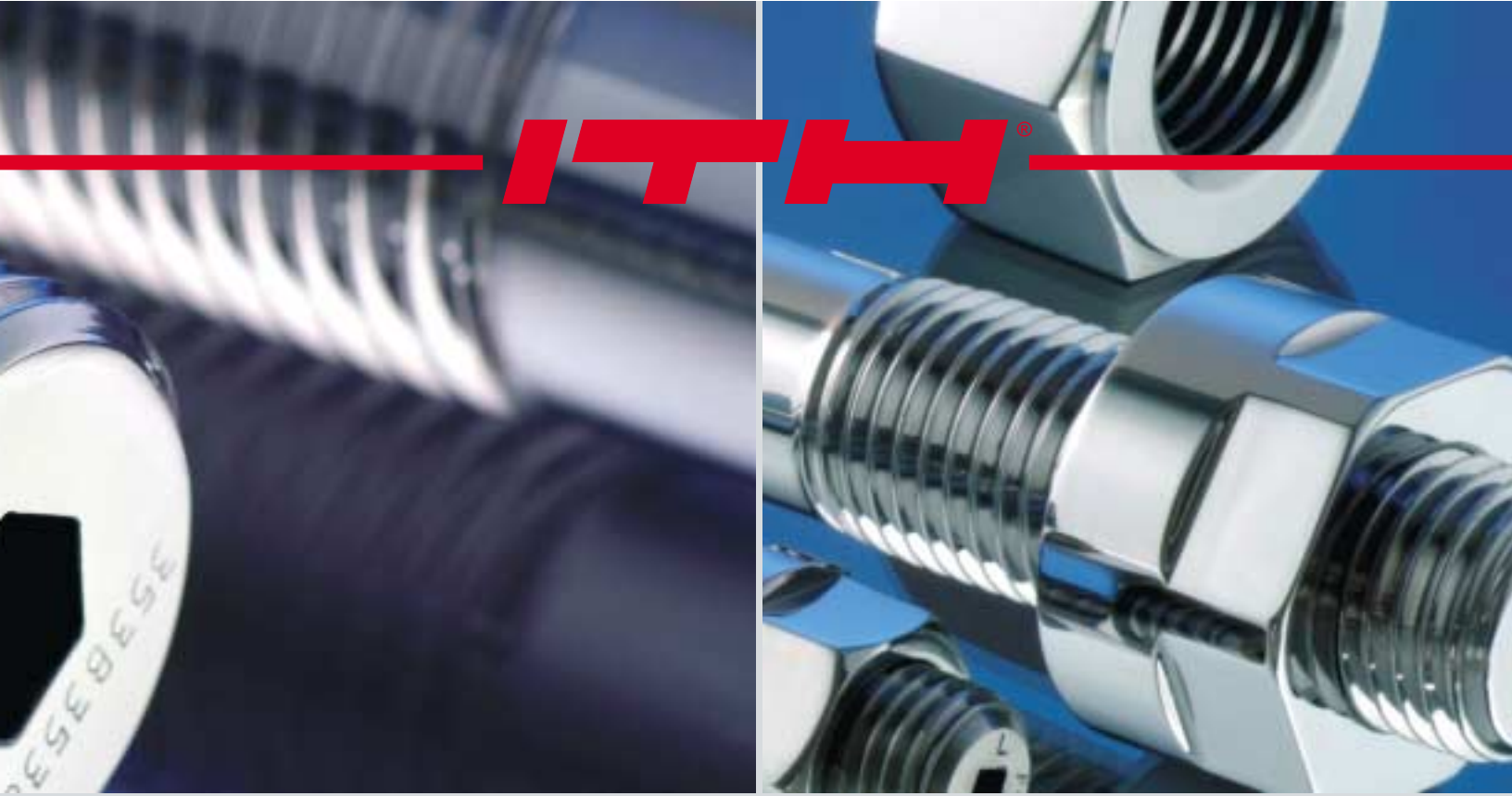

ITH Fastening Elements

ITH round nuts, type RMZ

are produced in standard sizes for threads of M30 (1") to M 125 (5").

The nuts have the following advantages:

- seating surface 90° to thread axis
- crack-free nuts as no forging process involved
- lower surface adjustment between nut and flange seat due to higher outer diameter
- no washer required
- material to EN 20898, other materials available on request
- radially smaller installation dimension than hexagon nut

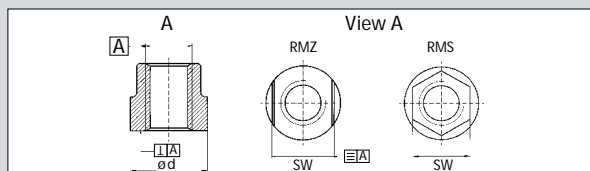

M	ød	SW _{max.}	M	ød	SW _{max.}
M 30	51	46,0	M 45	77	70,0
M 33	56	50,0	M 48	83	75,0
M 36	61	55,0	M 52	94	80,0
M 39	67	60,0	M 56	94	85,0
M 42	71	65,0	M 64	105	95,0

(Other sizes available on request)

Order no.

40.00 123 - M30 / 10

ITH fastening element
 Round-nut type RMZ; RMS=124
 Thread
 Quality (material)

ITH washers

are produced in standard sizes for threads of M20 (3/4") to M 100 (4").

The nuts have the following advantages:

- high plane parallelism
- high bending strength therefore lower loss of pre-tensioning force
- easy procurement and manufacture with special materials
- all ITH washers are dimensionally matched to ITH bolt-tensioning cylinders

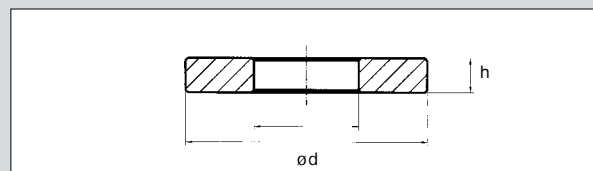

For thread	ød	h	For thread	ød	h
M 20	51	5	M 36	84	11
M 24	59	6	M 42	98	11
M 27	65	7	M 48	112	12
M 30	73	8	M 56	129	15
M 33	79	9	M 64	146	17

(Other sizes available on request)

Order no.

40.000 43 - W42 / 10

ITH fastening element
 ITH washer
 Thread
 Quality (material)



ITH nut runner, wind-power unit, sliding bearing



ITH torque wrench type DV Oxygen-fission plant



ITH bolt-tensioning cylinder, type RMZ

ITH® ITH Products in Use

Areas of use for ITH fastening elements

ITH system supplier

ITH is a system supplier offering a complete package consisting of the fastening elements and the appropriate tensioning tools.

Leading market position through:

- worldwide sales network
- international patents
- expert advice on all bolting applications by qualified mechanical engineers (not salesmen)
- decades of experience in bolting technology
- lean production
- fast service



Rothe Erde large-size anti-friction bearing



4-stroke ship's diesel engine



Gas turbine

